

# PREFAB MODULAR OFFSITE

## ARDEX PREFAB MODULAR SYSTEMS

Product Guide

[www.ardexamericas.com](http://www.ardexamericas.com) • [www.wwhenry.com](http://www.wwhenry.com)



*Building tomorrow*

**HENRY**

**BUILT BY  
YOU**  
backed by **ARDEX**



# ARDEX SUPPORTS PREFAB, MODULAR OFF-SITE

As an alternative to conventional construction, off-site manufacturing ensures quicker, safer, more sustainable, and a highly efficient building delivery.

The OFFSITE Industry is a uniquely distinguished, construction sector that requires specialized products to achieve the best possible efficiency.

Through innovation, technology and performance-driven products and systems, ARDEX develops OFFSITE solutions suitable to your specific applications and tailored to your manufacturing process.

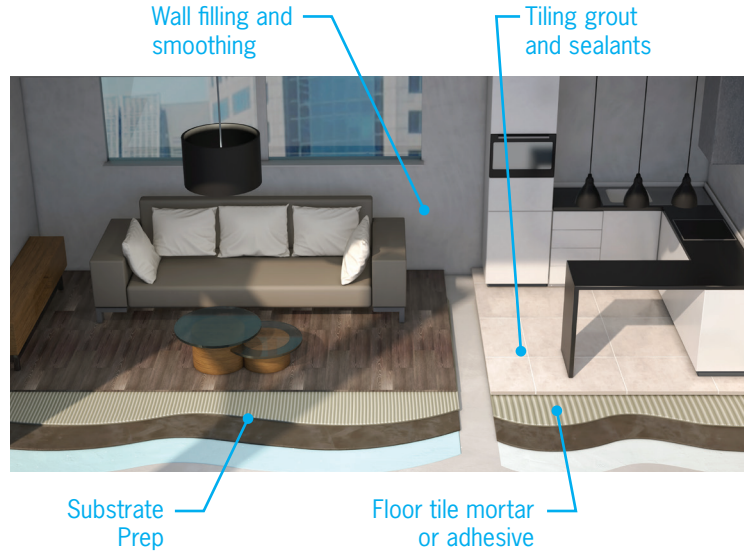

Scan here to watch the video!

## Construction Segments

- Prefab
- Modular / Volumetric (PPVC)
- Precast / Prestressed
- Prefabricated Bathroom Units/ Pods (PBU)
- Panelized
- Component



## Global Project Services

**The Global Project Services (GPS) program focuses on providing architects, designers and engineers assistance in selecting and specifying ARDEX products in various locations worldwide.**

Construction practices are diverse throughout the world and each project is unique, requiring different products based on location, environment and application. ARDEX manufactures a unique and diverse portfolio of specialty building products to meet the needs of local markets. Architects, designers and engineers who are working on an international project can contact their GPS Representative to assist them in selecting the appropriate ARDEX product based on the location of their project.

### GPS Advantages

- International product selection and specification assistance
- ARDEX system solution
- Local distribution information
- Installer recommendations
- Technical and jobsite support
- Customer service
- Warranty program information
- Environmental information



# PREFABRICATED BATHROOM UNITS/PODS

The floor in a prefab bath unit serves several critical purposes including, structural support, waterproofing, ease of installation, drainage, aesthetic finish, insulation, and comfort.

By fulfilling these purposes, the floor ensures that the bathroom is safe, functional, and comfortable for users while being efficient to install and maintain.

ARDEX delivers cutting-edge technology in substrate preparation with floor patches, self-leveling underlayments, and adhesives.

ARDEX patches and SLUs provide a flat and smooth surface for the floor covering.

Lightweight screeds and SLUs can provide significant weight reduction in modular construction.

Whether the adhesive is rolled or troweled, ARDEX can supply or develop the appropriate product and integrated system.

The ARDEX Group also provides a variety of solutions for wall and floor structures, enabling significant weight reduction in bathroom modules.

By using ARDEX TLT™ Building Panels, lightweight room construction becomes feasible.

This reduction in weight is facilitated by employing XPS panels instead of CBU.

ARDEX products are particularly well-suited for transporting and maneuvering PBU's during transit and on-site installation.

ARDEX products and systems excel in providing high bond, tensile, and flexural strength in setting mortars and grouts.



# ARDEX PREFAB MODULAR SYSTEMS BUILDING PANELS

## ARDEX TLT™ Building Panels

ARDEX TLT™ Building Panels offer builders and tile contractors a strong, lightweight, waterproof, and vapor-resistant tile base for wet areas. They are XPS foam panels manufactured with a proprietary blend of synthetic polymer mortar and an alkali-resistant fiber mesh. This gives the ARDEX TLT™ Building Panels a highly rigid structure and exceptional bonding strength.

1. Alkali-resistant glass fiber mesh
2. Polymeric cement mortar
3. XPS Foam
4. Polymeric cement mortar
5. Alkali-resistant glass fiber mesh

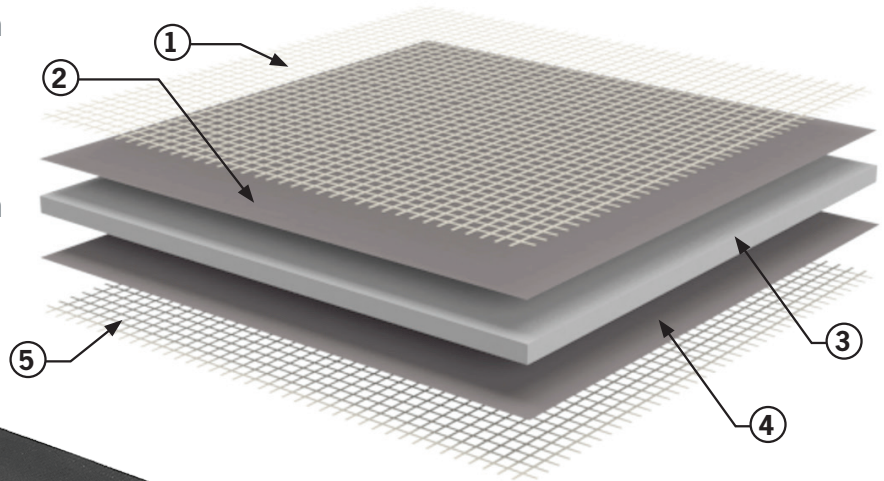

Pair with ARDEX TLT™  
Screws and Washers

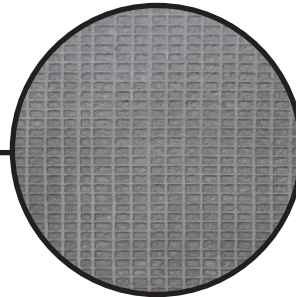

## ARDEX Modular Uncoupling and Heat Membrane Systems

### ARDEX FLEXBONE® HEAT Membrane In-Floor Heating Systems, 3-in-1 Membrane

- Easy to place, highly efficient cables
- Wi-Fi Thermostat; Google and Alexa compatible
- 3-in-1 In Floor Heating, Uncoupling and Waterproofing



### ARDEX UI 740™ FLEXBONE® Uncoupling Membrane

- Ideal for large format and gauged panel tile
- Simplifies tile installation, reducing time and labor costs, maximizing efficiency
- Maximum shear protection
- Evenly distributes stress, minimizing damage from point loads or minor movements
- Preserves floor integrity and appearance in prefab/modular construction



# ARDEX TLT™ PREFAB MODULAR SHOWER SYSTEMS

ARDEX TLT™  
BUILDING PANELS

1

ARDEX TLT™  
WATERPROOFING  
ACCESSORIES

2

ARDEX TLT™  
NICHES

3

ARDEX TLT™ 700  
(on seams and screwheads)

4

ARDEX TLT™  
DRAIN KITS

5

ARDEX TLT™  
SHOWER BASES

6

ARDEX TLT™  
CURBS

7

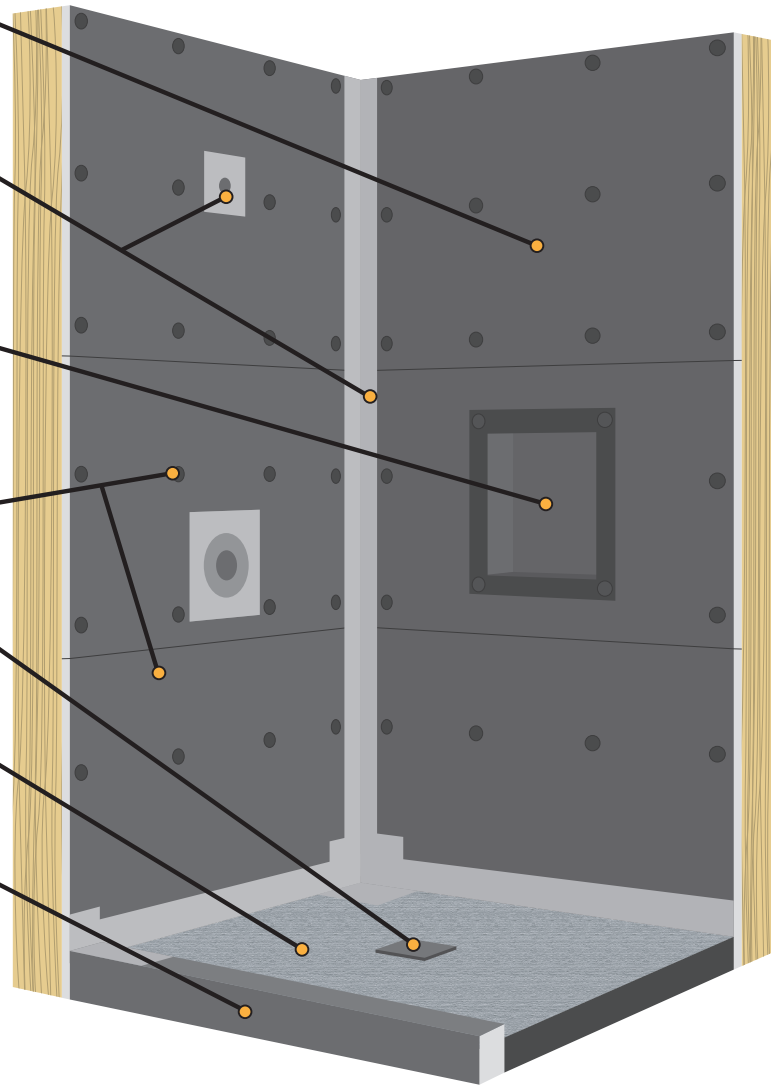

## Shower System Accessories

### Customized Shower Bases

Quick turnaround! Any shape, any size!  
State of the art XPS foam cutting  
machine can produce any shape!

3

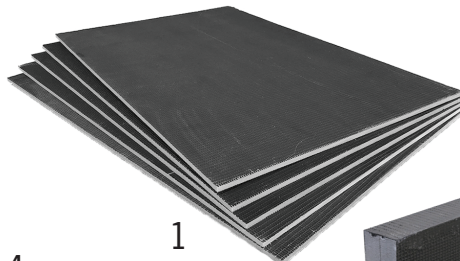

1

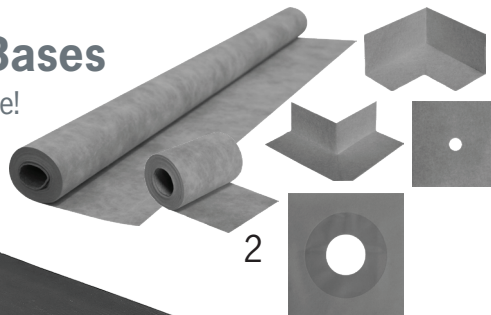

2

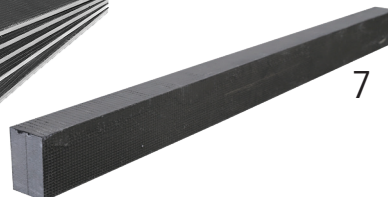

7



5



6

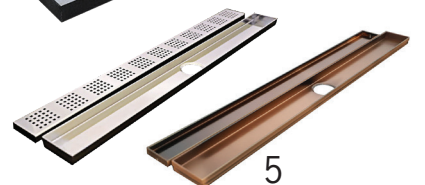

5

# ARDEX PREFAB SHOWER SYSTEM BASES

## ARDEX TLT™ Shower Bases

### Shower Bases for Shower Systems

- Pre-sloped, waterproofed, and designed to make tiled shower installations quicker and easier than traditional mud-bed installations
- Can easily be cut down to size or extended using dry pack mortar
- All shower bases have a patent pending, built-in drain assembly included

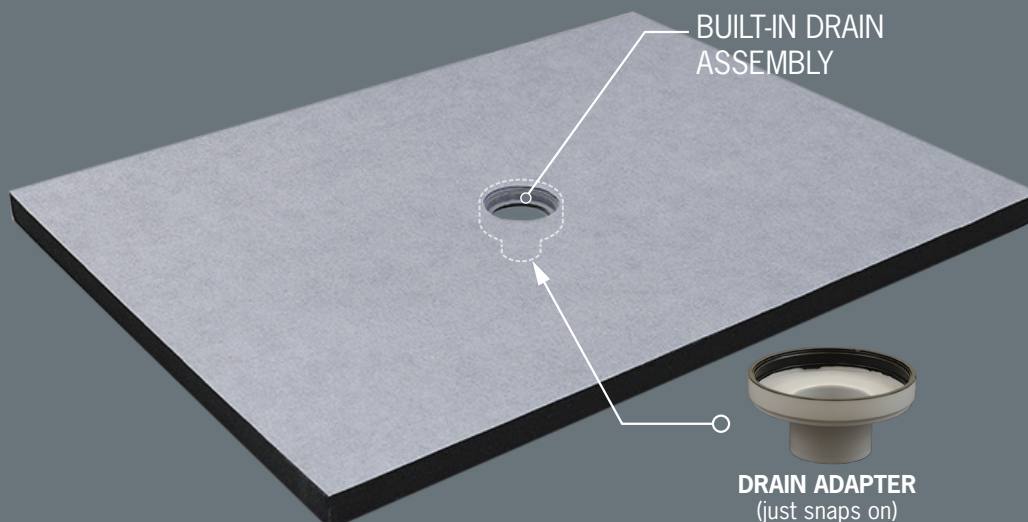
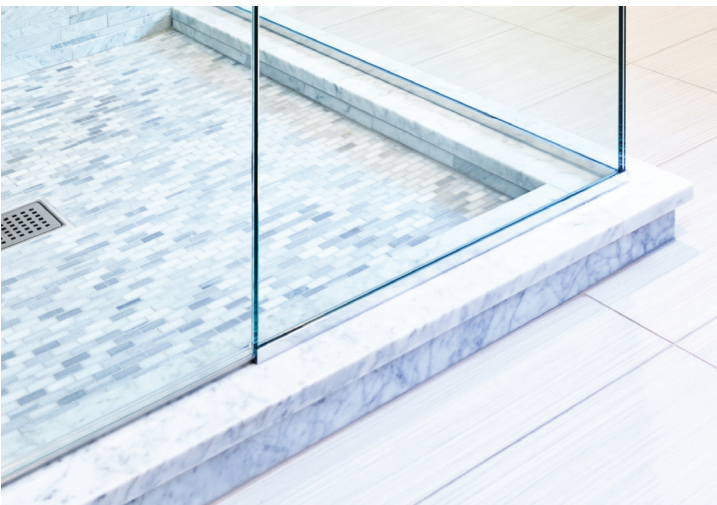
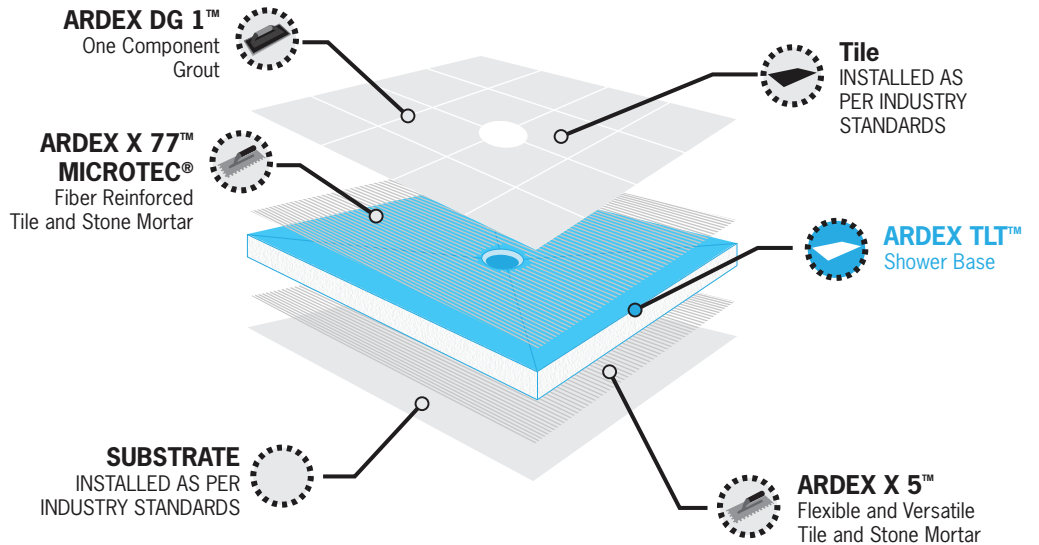

# ARDEX PREFAB SHOWER SYSTEM BASES

## ARDEX TLT™ Shower Bases

**APPLICATION:** The ARDEX TLT™ Shower Base is an all-in-one solution that sets new standards. It can be installed easily, quickly and securely.

**SIMPLY SECURE & WATERTIGHT:** Thanks to sophisticated technology and high-quality materials, end users will be able to enjoy a shower system which provides both high durability and excellent sealing properties.

**MAXIMUM COMPRESSION STRENGTH:** ARDEX TLT™ Shower Bases can be safely covered with any type of tile, as well as with natural stone. Small mosaic tiles  $\geq 20$  mm (3/4") can be laid without any problem.

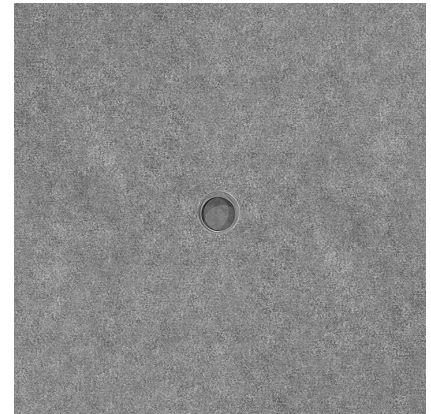

48" x 48" Center Drain

Center Drain Shower Bases	
Dimensions	
32" x 60"	(81 cm x 152 cm)
36" x 48"	(91 cm x 122 cm)
36" x 60"	(91 cm x 152 cm)
48" x 48"	(122 cm x 122 cm)
48" x 72"	(122 cm x 183 cm)
72" x 72"	(183 cm x 183 cm)

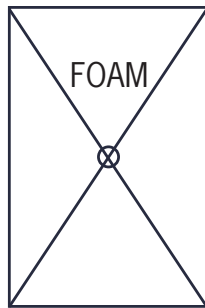

48" x 72"

Off-Center Drain Shower Bases	
Dimensions	
32" x 60"	(81 cm x 152 cm)
36" x 60"	(91 cm x 152 cm)

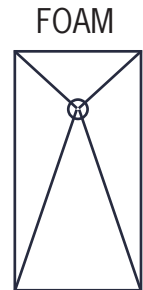

36" x 60"

## CUSTOM ARDEX TLT™ Shower Bases

- Quick production turnaround
- Any shape, any size
- For complete information, contact your local ARDEX Sales Professional

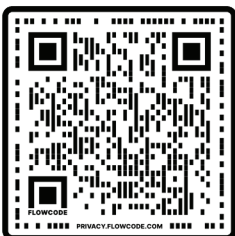

Scan to download ARDEX TLT™ Custom Shower Bases order form.

ARDEX tile&stone  
Installation Systems

ARDEX TLT™ Custom Shower Bases  
Order Form

**Sold To (CONTRACTOR):**

Name \_\_\_\_\_ Email Address \_\_\_\_\_

Company Name \_\_\_\_\_

Street Address \_\_\_\_\_ Order Number \_\_\_\_\_ Job/P.O. Number \_\_\_\_\_

State/Zip \_\_\_\_\_ Phone Number \_\_\_\_\_ Requested Delivery Date \_\_\_\_\_

Title/ User Type \_\_\_\_\_

**Ship To (ARDEX DISTRIBUTOR):** \_\_\_\_\_ Job/PO: \_\_\_\_\_ Quantity: \_\_\_\_\_

Company Name \_\_\_\_\_

Street Address \_\_\_\_\_

State/Zip \_\_\_\_\_ Phone Number \_\_\_\_\_

**Example: write-in dimensions for your custom base.**

Custom bases cannot exceed a width of 78 inches or a length of 96 inches. The measurement from the wall to the center of the drain must be at least 8 inches.

Perimeter thickness will vary according to the custom base size and drain location. Every custom base is made with a minimum 2% slope from perimeter to drain.

Drain assembly included.

**Sketch your Custom Shower Base here. Provide all dimensions and placement of drain as shown in example above.**

# ARDEX PREFAB MODULAR SYSTEMS FOR TILE & STONE INSTALLATIONS

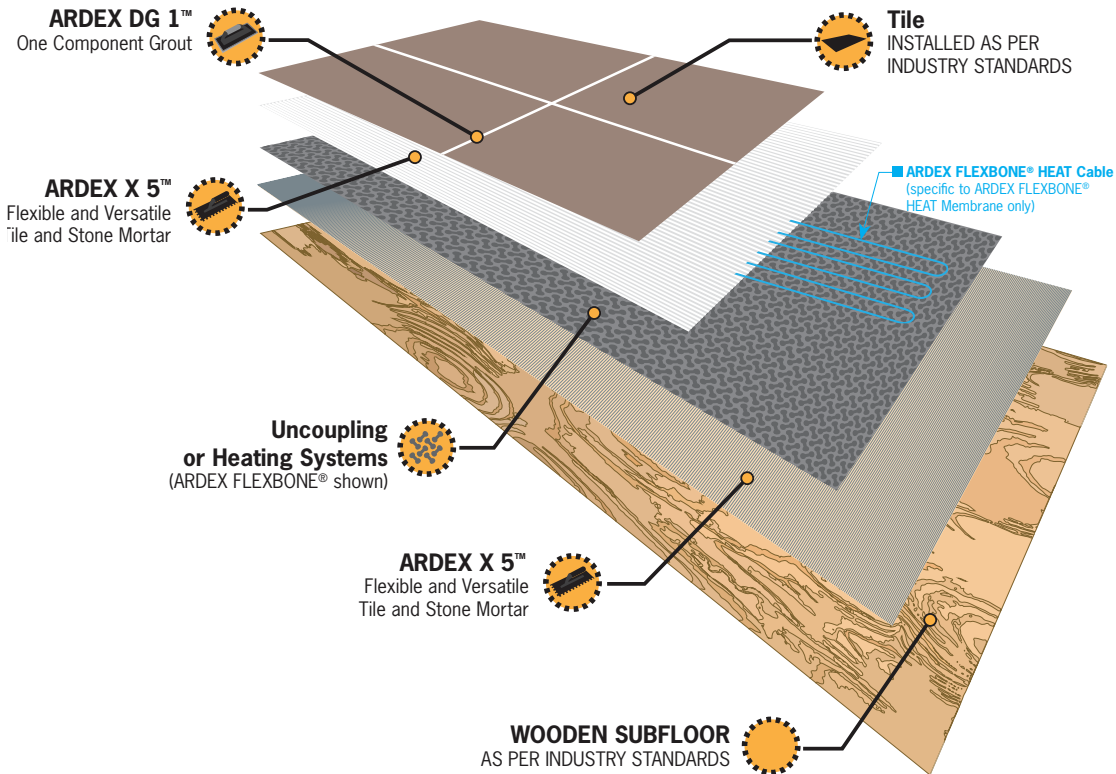

Check flooring manufacturer recommendations

# ARDEX PREFAB MODULAR SYSTEMS FOR TILE & STONE WITH WATERPROOFING

ARDEX waterproofing products provide complete protection for any wet application ranging from showers, bathrooms, PBU's, steam rooms and fitness centers.

Choose either a fast drying, two-component, cement-based waterproofing membrane, or a single-component, easy-to-use waterproofing membrane, both providing crack isolation.

ARDEX also offers a sheet applied waterproofing membrane with the lowest perm rating in the industry. It is ideally suited for steam showers.

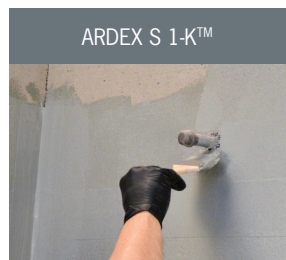
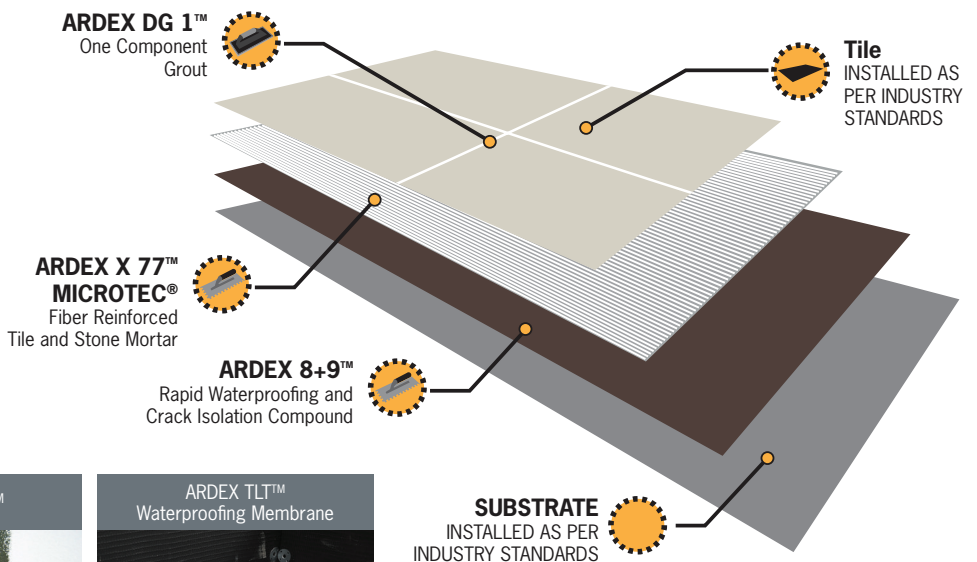

Check flooring manufacturer recommendations



# ARDEX PREFAB MODULAR SYSTEMS FOR VINYL FLOORING OVER WOODEN SUBSTRATES

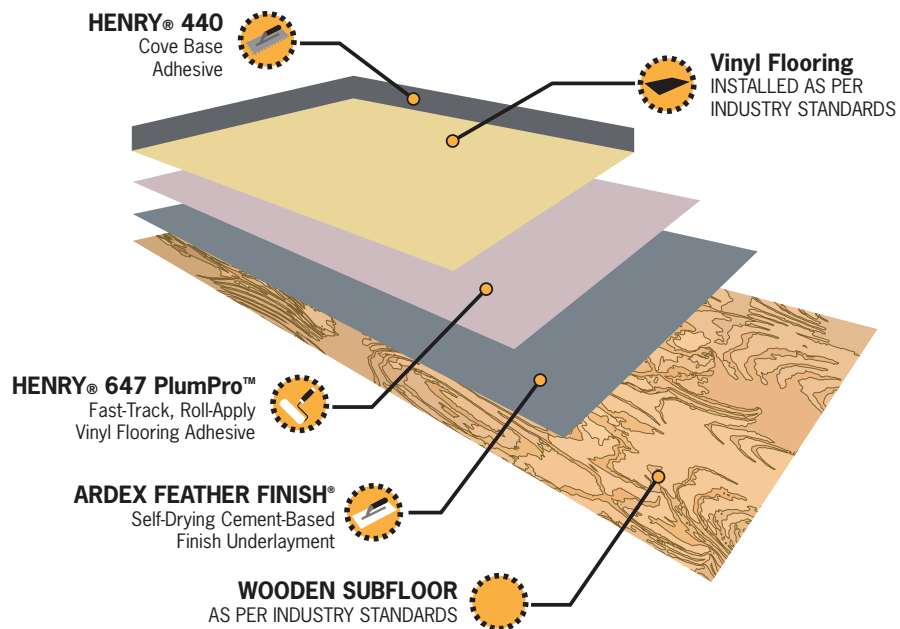

Check flooring manufacturer recommendations

# ARDEX PREFAB MODULAR SYSTEMS FOR VINYL FLOORING OVER CONCRETE PANEL SUBSTRATES

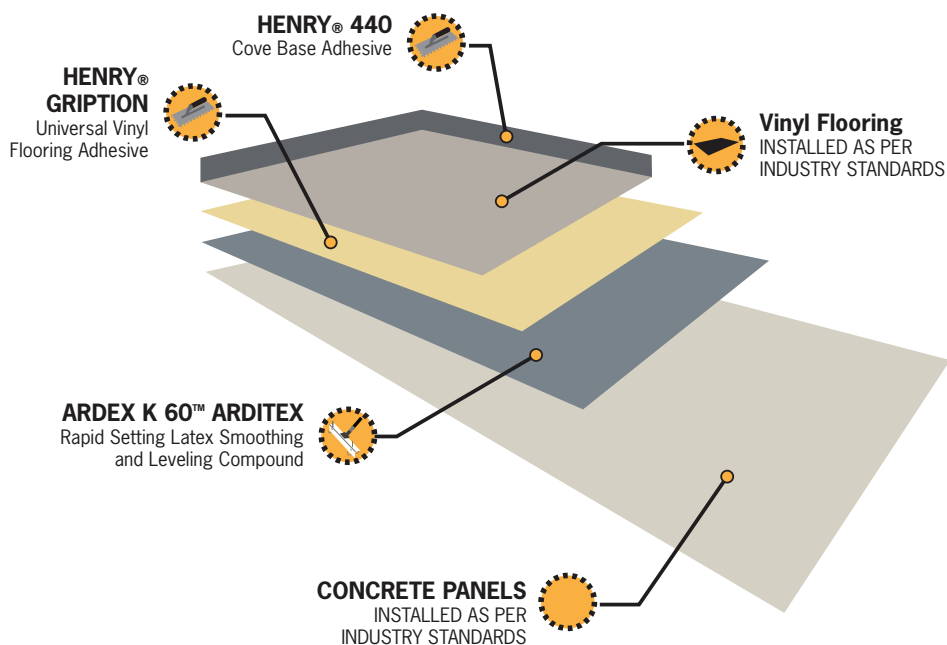

Check flooring manufacturer recommendations



**systemONE**<sup>™</sup>  
warranty

**ARDEXacademy**  
TRAINING EXCELLENCE

As an OFFSITE manufacturer, you can be liable for costly installation failures. Our warranties protect you from product failures when you follow proper installation techniques and standards in the industry. We're so confident in the quality of our products, our SystemOne™ warranty goes beyond covering just the cost of the replacement product. SystemOne™ is a full replacement warranty, and includes all materials and labor needed to make the repairs.

ARDEX Americas technical training programs and seminars have been recognized as the best in the industry. ARDEX Americas technical training seminars provide classroom and hands-on training where attendees work directly with ARDEX high-performance products.

At the Academy or on your factory floor, you and your team can receive hands-on training from the instructors with decades of experience. The ARDEX Academy offers trainings for Subfloor Preparation, Moisture Control, Tile & Stone Installation Systems, HENRY® Adhesives, ARDEX Surfaces and Engineered Concrete Repair Systems (ECRS).

Connect with ARDEX online! Read articles about industry trends, featured installations (like the one pictured) and connect with other ARDEX enthusiasts. You'll stay up-to-date on our upcoming events, like trade shows, demo days, and even educational webinars!



# ARDEX PREFAB MODULAR SYSTEMS

## Product Guide



*Building tomorrow*

**HENRY**

**BUILT BY  
YOU**  
backed by **ARDEX**



[www.ardexamericas.com](http://www.ardexamericas.com) • [www.wwhenry.com](http://www.wwhenry.com)